



## PNEUMATIC CONVEYOR WX52

The pneumatic conveyor model WX52 is the ideal solution to load granular biomass at considerable distance with rate flow up to 500kg/h.

- ⇒ IDEAL SOLUTION TO FEED INDUSTRIAL HEATING PLANTS
- ⇒ AUTOMATIC OPERATION
- ⇒ ADAPTABLE TO ANY HEATING SYSTEM
- ⇒ CHRONO TIME SETTING
- ⇒ MOTOR PROTECTION THROUGH SOFT START
- ⇒ IT WORKS 24H /24

### Standard equipment

- ◇ Electrical display
- ◇ Self-cleaning filter cartridge
- ◇ Level sensor
- ◇ Exhaust valve product
- ◇ Alimentation cable sensor 20 mt

CLEANING SYSTEM  
PULSE AIR-JET



INVERTER / SOFT START

IT WORKS 24H /24

INTERNAL CYCLONE

MODEL	Unit of measure	WX52	WX52i
Rated electrical power	kW	1,5	2,2
Rated voltage	V	380 (soft start)	220 (inverter)
Rated frequency	Hz	50	50
Internal hopper capacity	lt	12	
Max vacuum rate	Mbar	250	275
Type of filter	/	Self-cleaning cartridge filter	
Pressure cleaning system	Air	6 bar	
Structure	material	Carbon steel	
Total weight	kg	95	97
Motor dimensions	mm	500x 500 x H 700	
IN/OUT hoses Ø	mm	Ø 60	
Hopper dimensions	mm	Ø 360 x H 1000	

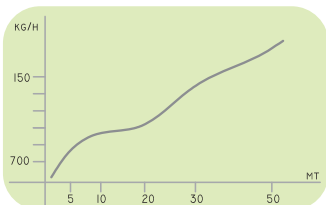
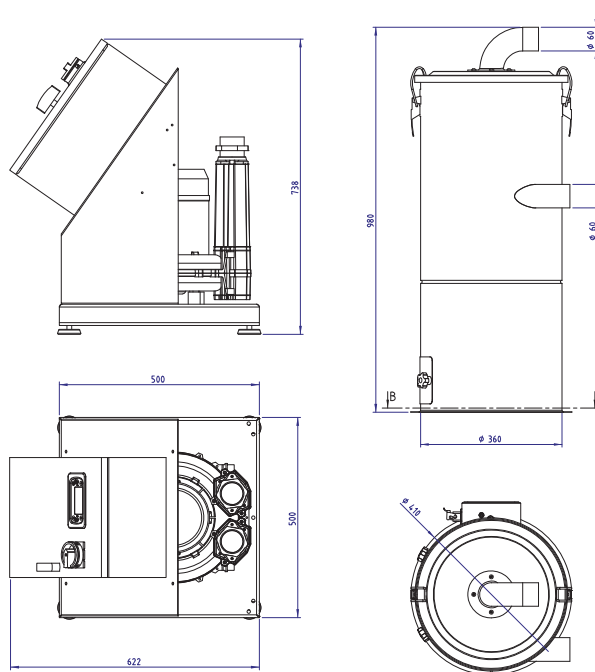

## Accessories

	Remote control KIT LAN/3G	ART NO
		KTE3G

	Automatic changeover unit	ART NO
		SPAUT04

	Tracking preseparator 150lt	ART NO
		PRC15

	Compression clamp Ø50	ART NO
		FS0002

	Manual changeover unit	ART NO
		PR0013

	Interception hopper	ART NO
		WX1005