



NEW CYCLONE
-50% DUST

EXCLUSIVE CLEANING FILTER
SYSTEM

PNEUMATIC CONVEYOR WX10

The WX10 pneumatic conveyor is the ideal solution for dosing granular biomass to automate your heating system with minimal costs and maintenance. It works as ash-cleaner too.

- ⇒ IDEAL SYSTEM TO FEED ANY PELLET BOILER
- ⇒ AUTOMATIC OPERATION
- ⇒ ADAPTABLE TO ANY HEATING SYSTEM
- ⇒ CHRONO TIME SETTING
- ⇒ REMOTE CONTROL PER 3G/LAN

Standard equipment

- ◇ Control panel with black-lit LCD display
- ◇ Polyester filter
- ◇ Level sensor
- ◇ Product exhaust valve
- ◇ Alimentation shuko cable 2 mt
- ◇ Sensor connection cable 10 mt

innovation for clean air

MODEL	Unit of measure	WX10
Electric rated power	W	1500
Rated voltage	V	110/220
Rated frequency	Hz	50/60
Internal hopper capacity	lt	5
Max vacuum rate	Mbar	275
Tipo di filtro	/	Self-cleaning cartridge
Structure	Material	Steel / ABS
Total Weight	kg	22
Motor Dimensions	mm	390 x 390 x H 498
IN/OUT hoses	mm	Ø 50
Hopper Dimensions	mm	Ø 280 x H 270

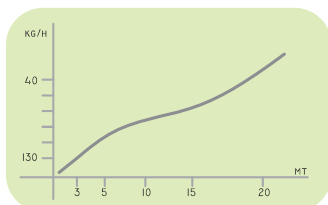
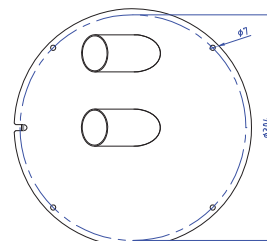
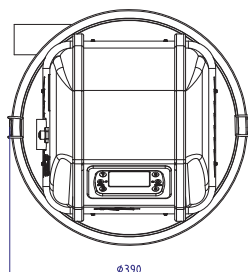
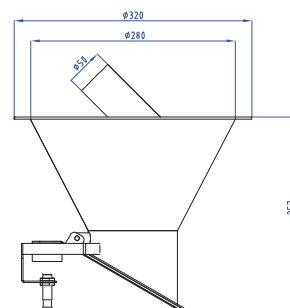
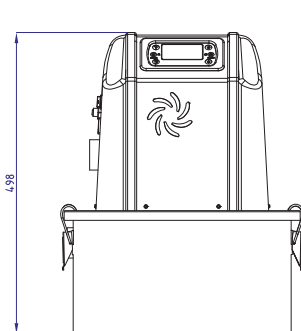

Accessories

	Suction probe	ART NO
		PR0001

	Flexible antistatic tube Ø 50 (min oder 20mt)	ART NO
		TB0001

	Ash preseparator	ART NO
		PRC01

	Hopper WX10M with motorized valve	ART NO
		WX1003

	Manual changeover unit	ART NO
		PR0013

	Interception hopper	ART NO
		WX1005