



INTERNAL CYCLONE



EXCLUSIVE FILTER CLEANING



PNEUMATIC CONVEYOR WX10C

The WX10C pneumatic conveyor is the ideal solution for dosing granular biomass to automate your heating system with minimal costs and maintenance. It works as ash-cleaner too.

- ⇒ IDEAL SYSTEM TO FEED BOILERS WITH DUSTY BIOMASS
- ⇒ AUTOMATIC OPERATION
- ⇒ ADAPTABLE TO ANY HEATING SYSTEM
- ⇒ CHRONO TIME SETTING
- ⇒ REMOTE CONTROL PER 3G/LAN

Standard equipment

- ◇ Control panel with black-lit lcd display
- ◇ Polyester cartridge filter
- ◇ Level sensor
- ◇ Exhaust valve product
- ◇ Alimentation shuko cable 2 mt
- ◇ Sensor connection cable 10 mt

MODEL	Unit of measure	WX10
Electrical rated power	W	1500
Rated voltage	V	110/220
Rated frequency	Hz	50/60
Internal hopper capacity	lt	6
Max vacuum rate	Mbar	275
Type of filter	/	Self-cleaning cartridge
Structure	Material	Steel / ABS
Total weight	kg	23
Motor dimensions	mm	390 x 390 x H 498
IN/OUT hoses	mm	Ø 50
Hopper dimensions	mm	Ø 280 x H 470

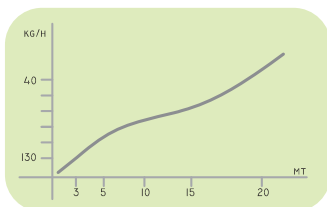
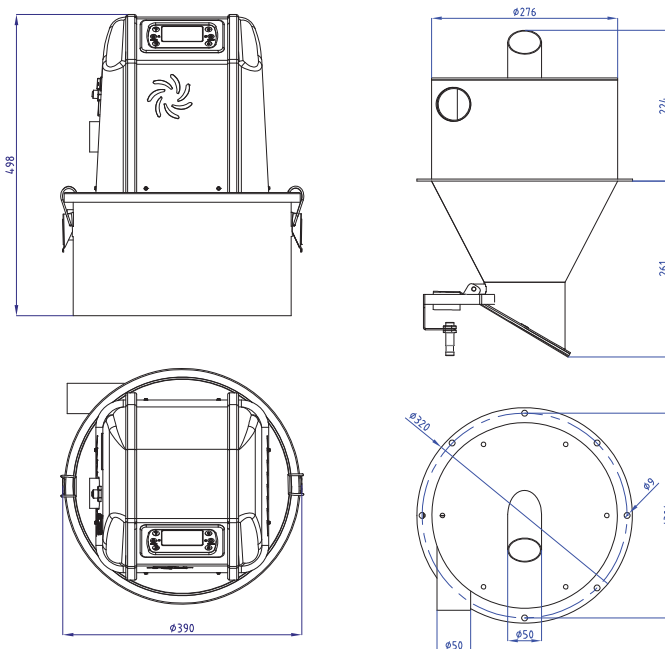

ACCESSORIES

	Rubber sleeve for hose Ø50	ART NO
		MG50E

	Sensor cable 20 mt	ART NO
		CV20

	Automatic changeover unit	ART NO
		SPAUT04

	Fluidising	ART NO
		SL0001

	Remote control kit LAN/3G	ART NO
		KTE3G

	Interception hopper	ART NO
		WX1005